



Wilmat Limited
 Wilmat House, 43 Steward Street, Birmingham, B18 7AE
 T 0121 454 7514 E sales@wilmat-handling.co.uk
 www.wilmat.co.uk
 Registered in England No. 6498876

Electric pallet truck WHMEB60



Standard

1.1	Brand		MiMA
1.2	Model		WHMEB60
1.3	Power type		Battery
1.4	Operation type		Stand on
1.5	Rated capacity	Q(kg)	6000
1.6	Load center	C(mm)	600
1.7	Load distance	x(mm)	980/925
1.8	Wheel base	y(mm)	1600/1545

Product size

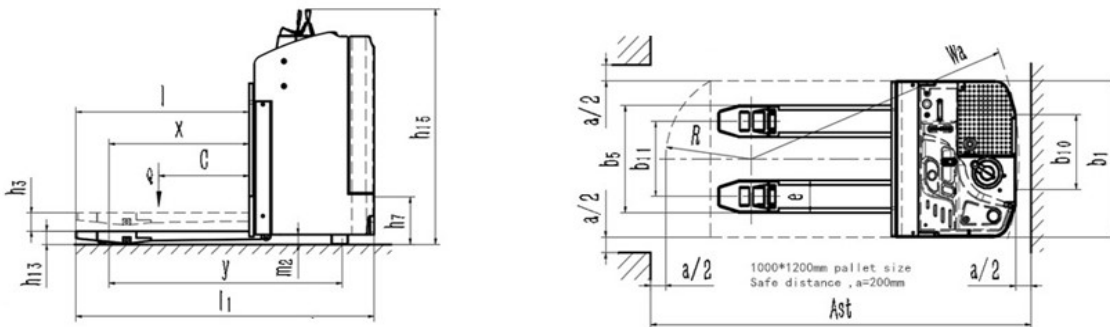

Size

2.1	Overall height	h15	1540
2.2	Lift height	h3(mm)	110
2.3	Stand board height	h7(mm)	300
2.4	Overall length	l1(mm)	2030
2.5	Overall width	b1(mm)	1000
2.6	Fork size	l/e/s(mm)	1200/235/86
2.7	Fork face min. ground clearance	h13(mm)	100
2.8	Fork outside width	b5(mm)	715
2.9	Body ground clearance	m2(mm)	60
2.10	Aisle width for pallet 1000*1200mm	Ast(mm)	2245
2.11	Aisle width for pallet 800*1200mm	Ast(mm)	2330
2.12	Turning radius	Wa(mm)	1890

Wheel

3.1	Wheel type		PU
3.2	Load wheel	mm	Φ85×145
3.3	Drive wheel	mm	Φ280×135
3.4	Auxiliary wheel	mm	Φ125×50
3.5	Number of wheels,load/drive(x=drive)+auxiliary		4/1X+2
3.6	Wheel tread, drive side	b10mm)	645
3.7	Wheel tread,load side	b11(mm)	480

Function			
4.1	Driving speed(load/unload)	km/h	5/6
4.2	Lifting speed(load/unload)	mm/s	18/35
4.3	Lowering speed(load/unload)	mm/s	65/10
4.4	Max.gradeability(load/unload)(S2-5min)	%(tanθ)	3/6
4.5	Brake type		Electromagnetic
Drive			
5.1	Drive motor (S2-60 min)	kw	4 (AC)
5.2	Lift motor (S3-15%)	kw	3.5 (DC)
5.3	Battery voltage/ capacity	V/Ah	24/420
5.4	Battery weight	kg	335
5.5	Steering System		EPS
Weight			
6.1	Service weight(incl. battery)	kg	1650
6.2	Axle capacity with full load,drive side/load side	kg	2640/5010
6.3	Axle capacity without load,drive side/load side	kg	1270/380
Other			
7.1	Battery replacement type		Side pull
7.2	Lithium battery voltage/capacity	V/Ah	24/200