



Wilmat Limited
 Wilmat House, 43 Steward Street, Birmingham, B18 7AE
 T 0121 454 7514 E sales@wilmat-handling.co.uk
 www.wilmat.co.uk
 Registered in England No. 6498876

Pedestrian Pallet Truck WHMEW20



Standard

1.1	Brand		MiMA
1.2	Model		WHMEW20
1.3	Power type		Battery
1.4	Operation type		Pedestrian
1.5	Load capacity	Q(kg)	2000
1.6	Load center	C(mm)	600
1.7	Front overhang	x(mm)	969
1.8	Wheelbase	y(mm)	1291

Product size

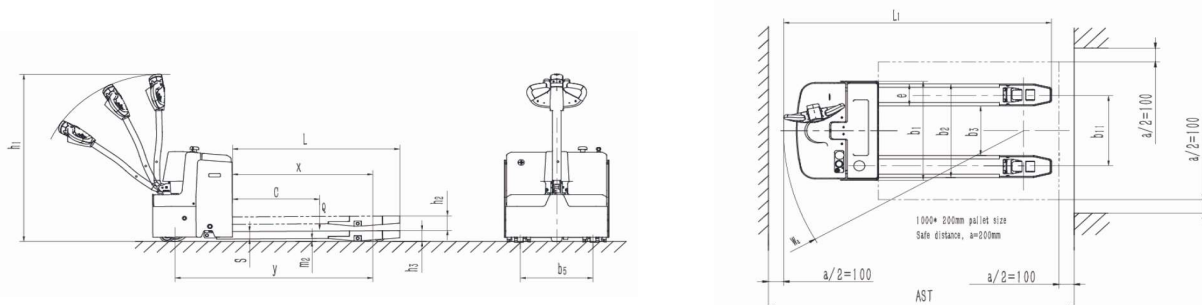

Size

2.1	Lift height	h13+h3(mm)	195
2.2	Handle height when operation	h1(mm)	760/1244
2.3	Fork face min.ground clearance	h3(mm)	85
2.4	Overall length	L1(mm)	1700
2.5	Overall width	b1(mm)	730
2.6	Fork size	l/e/s(mm)	1150/160/45
2.7	Fork outside width	b1(mm)	680
2.8	Fork ground clearance	m2(mm)	40
2.9	Aisle width for pallet 1000×1200mm (C=500mm)	Ast(mm)	1990
2.10	Aisle width for pallet 800×1200mm (C=600mm)	Ast(mm)	2040
2.11	Turning radius	Wa(mm)	1600

Wheel

3.1	Wheel type		PU
3.2	Load wheel	(mm)	φ78×70
3.3	Drive wheel	(mm)	φ210×70
3.4	Auxiliary wheel	(mm)	φ100×40
3.5	Number of wheels, front/rear (x=drive wheel)		4 /1x+2
3.6	Wheel tread, drive side	b4(mm)	500
3.7	Wheel tread, load side	b5(mm)	530

Function			
4.1	Driving speed(load/unload)	(km/h)	3.6/3.7
4.2	Lifting speed(load/unload)	(mm/s)	39/46
4.3	Lowering speed(load/unload)	(mm/s)	46/40
4.4	Max. gradeability(load/unload)(S2-5min)	%(tan θ)	3/10
4.5	Brake brake		Electromagnetic
Drive			
5.1	Driving motor(S2-60 min)	(kw)	0.75(DC)
5.2	Lifting motor(S3-15%)	(kw)	0.8(DC)
5.3	Battery voltage/capacity	(V/Ah)	24/100
5.4	Battery weight	(kg)	70
5.5	Steering system		Mechanical
Weight			
6.1	Service weight(incl.battery)	(kg)	400
6.2	Axle capacity with full load,drive side/load size	(kg)	850/1550
6.3	Axle capacity with no load,drive side/load size	(kg)	310/90
Other			
7.1	Battery replacement type		Hoisting