

**Electric pallet truck WHME15L/20L**

|    |  |                                      |             |             |
|----|--|--------------------------------------|-------------|-------------|
| 1  | Model  |                                      | WHME15L     | WHME20L     |
| 2  | Drive type                                     |                                      | Electric    | Electric    |
| 3  | Operation type                                 |                                      | Pedestrian  | Pedestrian  |
| 4  | Load capacity                                  | Q (t)                                | 1.5         | 2.0         |
| 5  | Load centre                                    | c (mm)                               | 600         | 600         |
| 6  | Distance between fork backrest and front wheel | x (mm)                               | 944         | 944         |
| 7  | Wheel base                                     | y (mm)                               | 1243        | 1243        |
| 8  | Tread  | b <sub>11</sub> (mm)                 | 400/535     | 400/535     |
| 9  | Lift Height                                    | h <sub>3</sub> (mm)                  | 200         | 200         |
| 10 | The height of handle in the operation position | h <sub>14</sub> (mm)                 | 740/1160    | 740/1160    |
| 11 | Lowered fork height                            | h <sub>13</sub> (mm)                 | 85          | 85          |
| 12 | Overall Length                                 | l <sub>1</sub> (mm)                  | 1603        | 1603        |
| 13 | Body Length                                    | l <sub>2</sub> (mm)                  | 453         | 453         |
| 14 | Overall Width                                  | b <sub>1</sub> / b <sub>2</sub> (mm) | 550/685     | 550/685     |
| 15 | Fork Size                                      | s/e/l (mm)                           | 50/150/1150 | 50/150/1150 |
| 16 | Fork Width                                     | b <sub>5</sub> (mm)                  | 550         | 550         |
| 17 | Ground clearance under mast                    | m <sub>2</sub> (mm)                  | 35          | 35          |
| 18 | Aisle width for pallets 1000*1200 crossways    | Ast (mm)                             | 1804        | 1804        |
| 19 | Aisle width for pallets 800*1200 lengthways    | Ast (mm)                             | 1854        | 1854        |
| 20 | Turning Radius                                 | Wa (mm)                              | 1398        | 1398        |

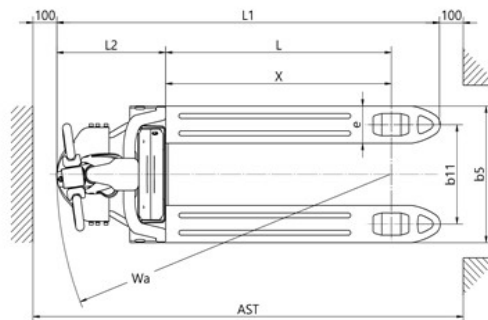
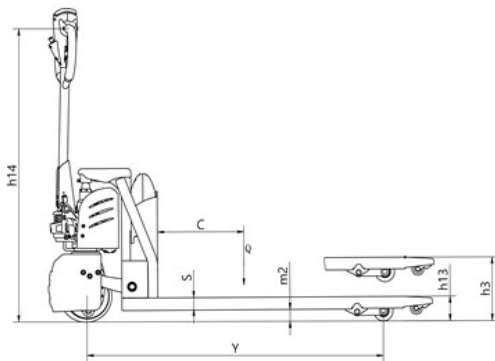

|    |  |         |                       |                       |       |       |
|----|--|---------|-----------------------|-----------------------|-------|-------|
| 21 | Driving Speed, load/unload                 | (km/h)  | 4.2/4.5               | 4.2/4.5               |       |       |
| 22 | Maximum gradeability load/unload           | (%)     | 5/10                  | 5/10                  |       |       |
| 23 | Brake Type                                 |         | Electromagnetic brake | Electromagnetic brake |       |       |
| 24 | Drive Motor                                | kw      | 0.75                  | 0.75                  |       |       |
| 25 | Lift Motor                                 | kw      | 0.8                   | 0.8                   |       |       |
| 26 | Lithium Battery voltage/rate capacity      | V/Ah    | 24/30                 | 24/60                 | 48/20 | 48/30 |
| 27 | Battery Weight (±5%)                       | kg      | 7.8                   | 13.2                  | 10.2  | 13.2  |
| 28 | Type of drive control                      |         | DC                    | DC                    |       |       |
| 29 | Noise level                                | (dB(A)) | ≤70                   | ≤70                   |       |       |
| 30 | Steering type                              |         | Manual steering       | Manual steering       |       |       |
| 31 | Wheel type                                 |         | PU                    | PU                    |       |       |
| 32 | Drive wheel                                | mm      | Φ210×70               | Φ210×70               |       |       |
| 33 | Balance wheel                              | mm      | Φ80×60                | Φ80×60                |       |       |
| 34 | Load wheel                                 | Φ×w(mm) | Φ50×30                | Φ50×30                |       |       |
| 35 | Qty of wheel, Front/Rear (x=driving wheel) |         | 1x/4                  | 1x/4                  |       |       |
| 36 | Service weight (without battery)           | kg      | 142                   | 146                   |       |       |